

TUBE CENTRAL :

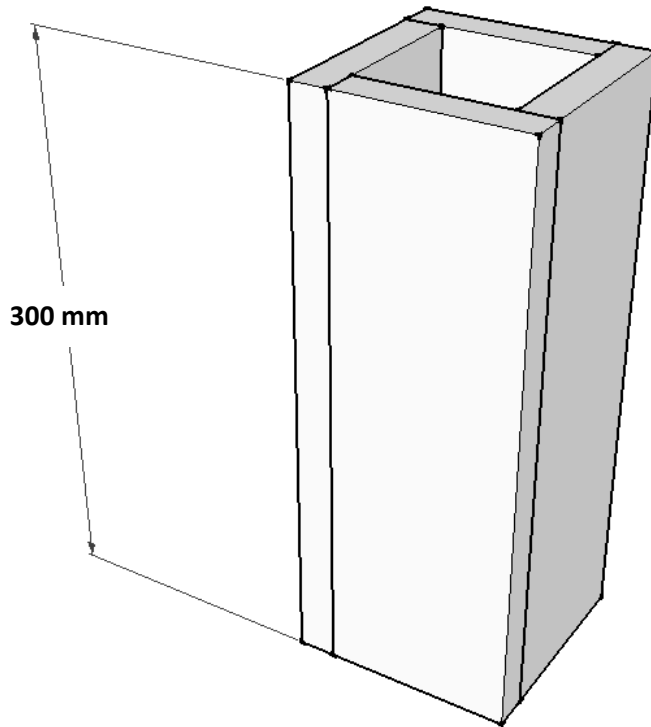

Matériaux :

Planche de 96 x 19 mm x 3.5 ml

Vis de 3 x 25 mm x 12 U

Vis de 3 x 45 mm x 16 U

Tirefond de 60 mm x 6 U

PIED À SAPIN

PLAN D'ENSEMBLE ET DE FABRICATION

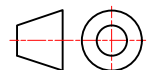

Rev : A

A4

FOLIO DT 1 / 3

Collège
AUDEMBRON

**ATELIER
HABITAT
SEGPA**

M.SPATOLA

Nom :

Prénom :

Classe :

4

1

3



2

1

1

H

G

F

E

D

C

B

A

H

G

F

E

D

C

B

A

4

1

3



2

1

1

Supports du tube central A :

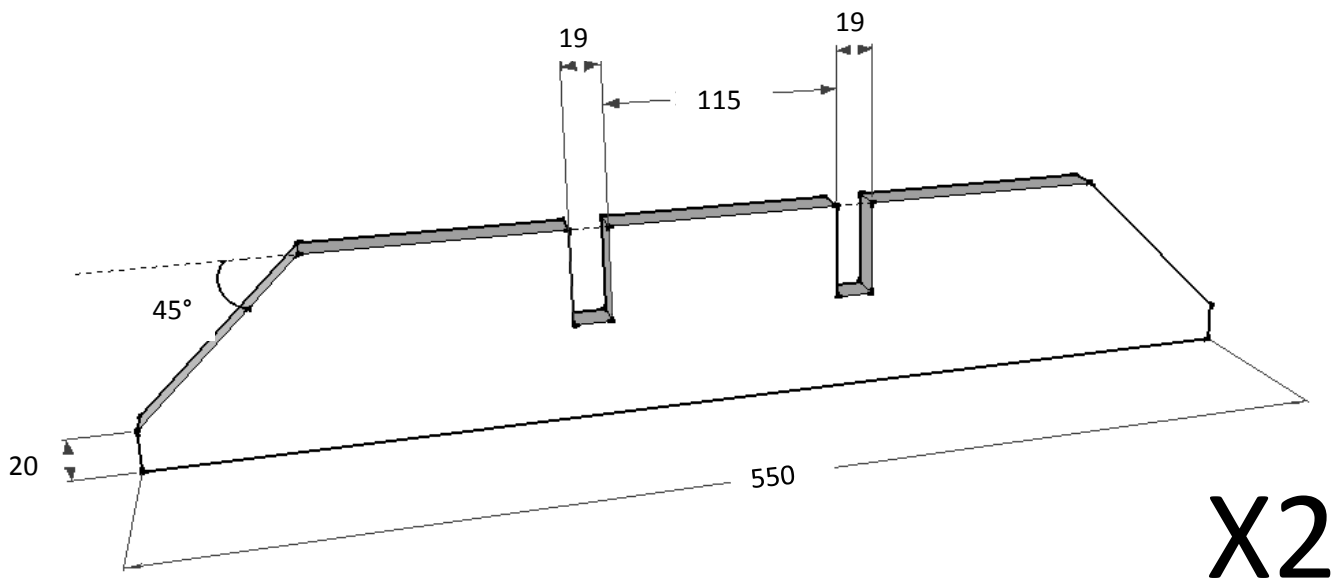

Supports du tube central B :

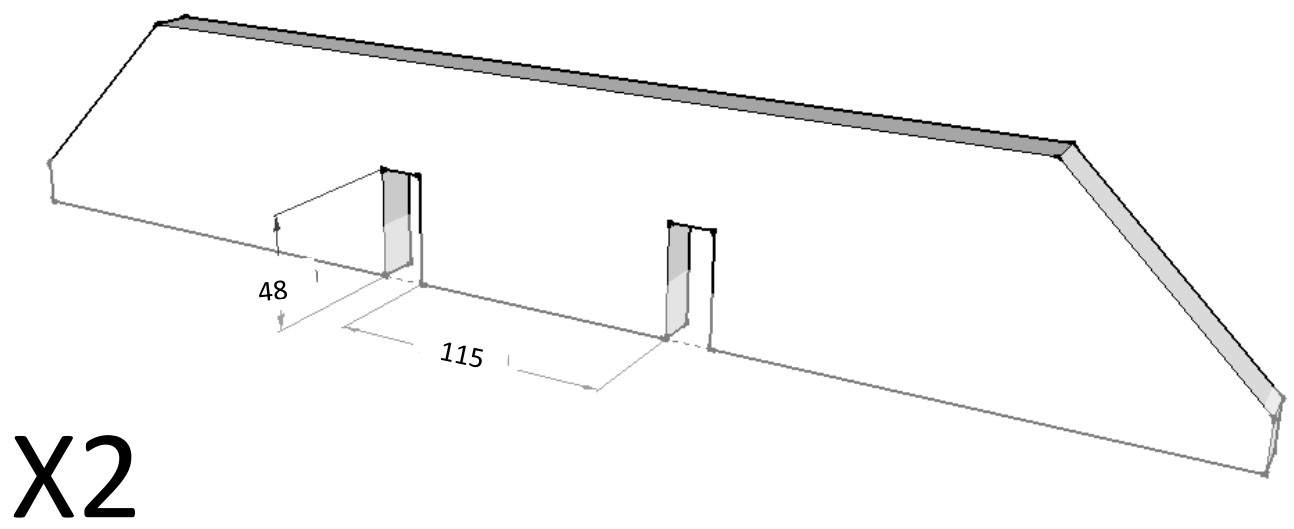

Collège
AUDEMBRON

ATELIER
HABITAT
SEGPA
M.SPATOLA

PIED À SAPIN

PLAN D'ENSEMBLE ET DE FABRICATION

Nom : _____ Prénom : _____ Classe : _____

Rev : A	A4
FOLIO DT 2 / 3	

Assemblage :

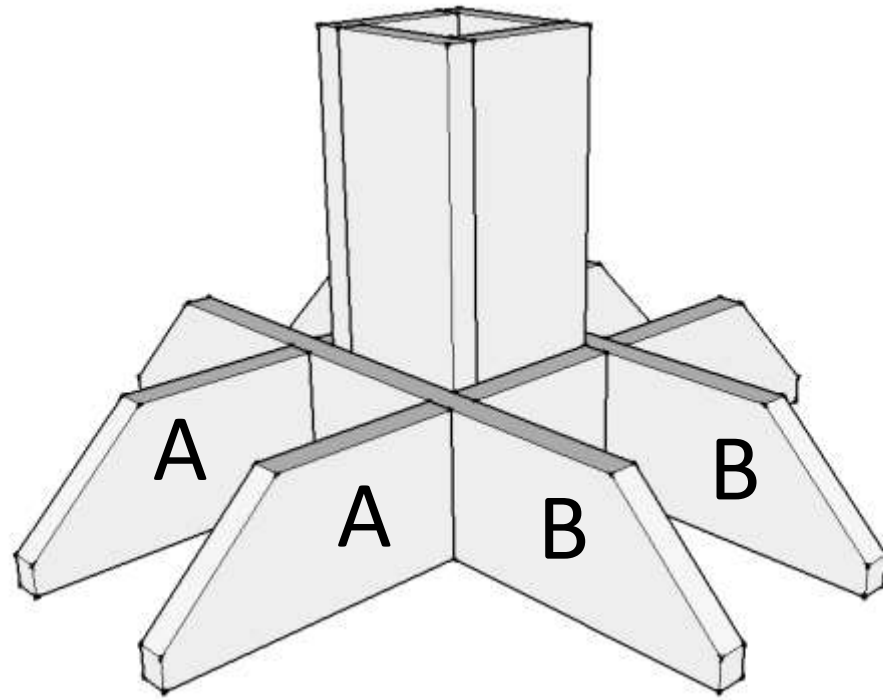

Disposition des tirefonds :

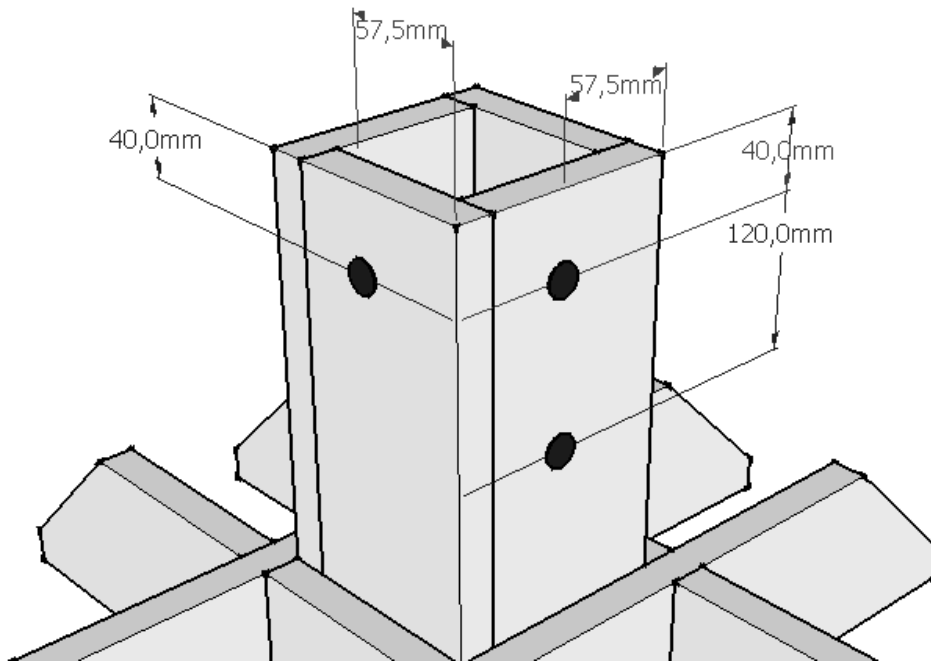

PIED À SAPIN

PLAN D'ENSEMBLE ET DE FABRICATION

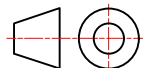

Rev : A | A4

FOLIO DT 3 / 3

Nom :

Prénom :

Classe :

Collège
AUDEMBRON

ATELIER
HABITAT
SEGPA

M.SPATOLA

4

1

3

1

2

1

1